

# Wiper DL

Manual

# Table of contents

<b>1 General information</b>	<b>3</b>
1.1 General information	3
1.2 Health and safety instructions	3
1.3 Warning notices	4
1.4 User and operating requirements	4
1.5 Intended use	4
1.6 Disposal instructions	5
1.7 Certificates and approvals	5
<b>2 Introduction</b>	<b>6</b>
2.1 Introduction	6
2.2 Scope of delivery	6
2.3 Product identification	7
<b>3 Commissioning</b>	<b>8</b>
3.1 Power supply	8
3.2 Mounting the wiper control unit	8
3.3 Adjusting the wipe angle	9
3.4 Installation instructions	10
<b>4 Application</b>	<b>19</b>
4.1 LED status indicator	19
4.2 Operating the Wiper DL	19
<b>5 Calibration</b>	<b>21</b>
<b>6 Malfunction and maintenance</b>	<b>22</b>
6.1 Maintenance of the wiper	22
6.2 Troubleshooting	22
6.3 Return shipment	22
<b>7 Technical data</b>	<b>24</b>
7.1 Technical specifications	24
<b>8 Accessories</b>	<b>25</b>
8.1 Accessories and spare parts Wiper DL	25
<b>9 Warranty</b>	<b>26</b>
<b>10 Technical support</b>	<b>27</b>
<b>11 Contact us</b>	<b>28</b>
<b>12 Index</b>	<b>29</b>
<b>13 Appendix</b>	<b>30</b>

# 1 General information

## 1.1 General information

Welcome to TriOS.

We are pleased that you have chosen the DL30 or DL200 wiper.

The Wiper DL is an automatic mechanical cleaning system for optical sensors. By regularly and gently brushing the optics, it removes deposits such as biofouling, sludge or dirt particles. This reduces the need for manual maintenance on site and the data quality remains stable even over long periods of use.

In this manual you will find all the information you need for installation, commissioning, operation and maintenance of the data logger-controlled wiper models. Technical specifications can be found in chapter 7.

Please note that the user is responsible for complying with regional and national regulations for the installation of electronic devices. Any damage caused by incorrect use or unprofessional installation is not covered by the warranty.

All sensors and accessories supplied by TriOS Mess- und Datentechnik GmbH must be installed and operated in accordance with TriOS Mess- und Datentechnik GmbH specifications. All parts have been designed and tested according to international standards for electronic instruments. The device complies with international standards for electromagnetic compatibility. Please use only original TriOS accessories and cables to ensure smooth and professional use of the devices.

Read this manual carefully before using the device and keep it for future reference. Before using the sensor, make sure that you have read and understood the safety precautions described below. Always ensure that the sensor is operated correctly. The safety precautions described on the following pages are intended to ensure problem-free and correct operation of the device and the associated accessories and to prevent you, other persons or devices from being harmed.

### NOTICE

**If translations differ from the original German text, the German version is binding.**

#### Copyright notice

All contents of this manual, in particular texts, photographs and graphics, are protected by copyright. Unless expressly indicated otherwise, the copyright lies with TriOS Mess- und Datentechnik GmbH. Persons who violate the copyright are liable to prosecution in accordance with § 106 ff of the Copyright Act and will also be warned and liable to pay compensation.

## 1.2 Health and safety instructions

This manual contains important information on health and safety regulations. This information is marked in accordance with the international specifications of ANSI Z535.6 (“Product safety information in product manuals, instructions and other collateral materials”) and must be followed. The following categories are distinguished:

### ⚠ DANGER

**Danger / Will cause serious injury or death**

### ⚠ WARNING

**Warnings / May cause serious injury or death**

## **⚠ CAUTION**

Caution / May cause moderate injury

## **NOTICE**

May lead to material damage



### Tip / Useful information

#### Electromagnetic waves

Devices that emit strong electromagnetic waves can influence the measurement data or cause the sensor to malfunction. Avoid operating the following devices in the same room as the TriOS sensor: cell phones, cordless phones, transceivers or other electrical devices that generate electromagnetic waves.

## 1.3 Warning notices

### General notices:

- Never attempt to disassemble or modify any part of the device unless specifically described in this manual. Inspections, modifications and repairs may only be carried out by the device dealer or by TriOS authorized and qualified specialists.
- Devices from TriOS Mess- und Datentechnik GmbH comply with the highest safety standards. Repairs to the devices (which include the replacement of the connecting cable) must be carried out by TriOS Mess- und Datentechnik GmbH or an authorized TriOS workshop. Incorrect, improper repairs can lead to accidents and injuries.

## **NOTICE**

**TriOS does not guarantee the plausibility of the measured values. The user is always responsible for monitoring and interpreting the measured values.**

## 1.4 User and operating requirements

The accessories have been developed for use in industry and science. The target group for operating the Wiper DL is technically experienced specialist personnel in companies, sewage treatment plants, waterworks and institutes.

## 1.5 Intended use

The DL30 and DL200 wiper are intended exclusively as an automatic mechanical cleaning system for optical sensors. Please observe the technical data. Any other use is considered improper.

According to current scientific knowledge, the device is safe to use if it is handled in accordance with the instructions in this manual.

## **NOTICE**

**Damage caused by improper use is excluded from the warranty.**

## 1.6 Disposal instructions

At the end of its service life or useful life, the device and its accessories can be returned to the manufacturer (see address below) for disposal in an environmentally friendly manner. Proof of prior professional decontamination must be provided in the form of a certificate. Please contact us before returning the device for further details.

### Address of the manufacturer:

TriOS Mess- und Datentechnik GmbH  
Bürgermeister-Brötje-Str. 25  
26180 Rastede  
Rastede, Germany  
Phone: +49 (0) 4402 69670 - 0  
Fax: +49 (0) 4402 69670 - 20

## 1.7 Certificates and approvals

The product meets all requirements of the harmonized European standards. It therefore fulfills the legal requirements of the EU directives. TriOS Mess- und Datentechnik GmbH confirms the successful testing of the product by affixing the CE mark (see appendix).

## 2 Introduction

### 2.1 Introduction

#### Main features

The Wiper DL offers the following advantages:

- Easy installation and operation
- Extremely low power consumption for long-term operation
- Adjustable wiping angle
- Slip clutch that protects the gearbox from damage if the wiper arm is bumped
- Brush design that has been extensively proven worldwide under extreme conditions
- Integrated self-monitoring for reliable operation; i.e. if the wiper arm is knocked in front of the optical window, it automatically moves to the side.

### 2.2 Scope of delivery

The DL30 wiper is supplied with the following components:

- Wiper unit, which holds the optical sensor
- Control module with microprocessor
- 10 m connection cable between wiper unit and control module
- 0.5 m connection cable from the control module to the TriBox3 (controller)

The DL200 wiper is supplied with the following components:

- Wiper unit, which holds the optical sensor
- Control module with microprocessor
- SubConn MCIL5M connection
- 0.5 m connection cable from the control module to the TriBox3 (controller)

The wiper unit consists of:

- Motor and gearbox
- Position detection of the wiper shaft

The control module consists of

- Microprocessor
- Trigger input connected to the control port of the data logger
- Adjustment system for wiping and parking angle
- LED status display

Keep the original packaging of the device for possible return shipment for maintenance or repair purposes.

## 2.3 Product identification

All TriOS Mess- und Datentechnik GmbH products are provided with a product label that clearly shows the product designation.

There is also a type plate on the device with the following information, which you can use to clearly identify the product:

### Wiper DL30

Serial number

Product type

Power supply



### Wiper DL200

Serial number

Product type

Power supply

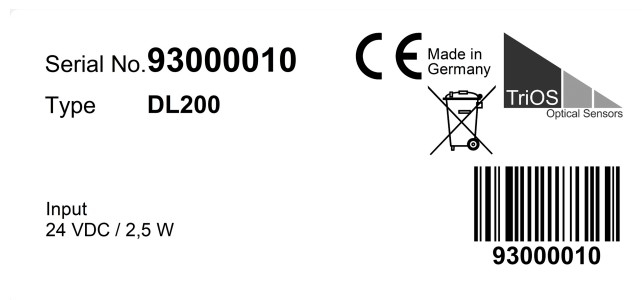

The nameplate also contains the product barcode, the TriOS Optical Sensors logo and the CE quality mark.

Please note that the specifications given here are for illustrative purposes only and may vary depending on the product version.

### 3 Commissioning

This chapter covers the commissioning of the Wiper DL up to the first function test. Please pay particular attention to this section and follow the safety instructions to protect the product from damage and yourself from injury.

#### Connection diagram

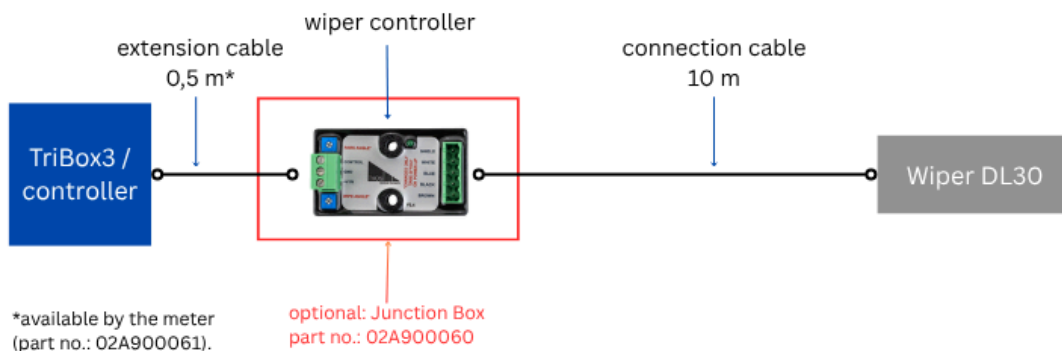

#### 3.1 Power supply

The control voltage must be set to +5 V for at least 10 ms to start a wiping process. The Wiper DL requires a power supply in the voltage range from 9 to 24 VDC.

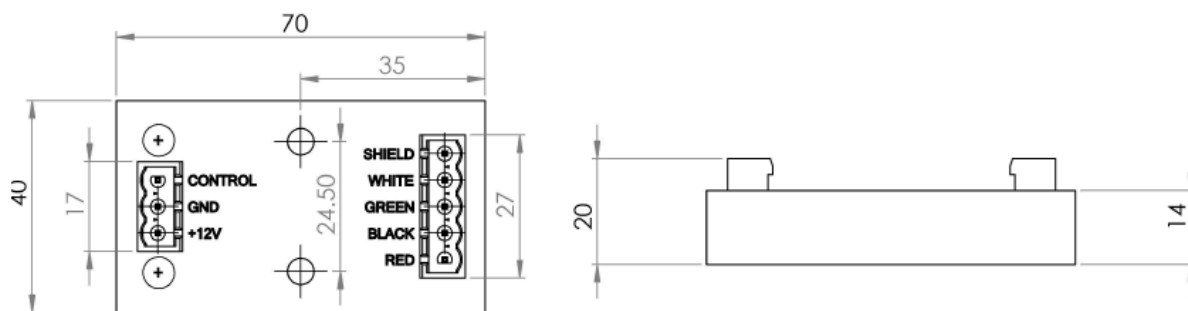

#### 3.2 Mounting the wiper control unit

The control unit for the wiper is not waterproof. It should be mounted in a weatherproof connection box (see chapter 8 Accessories: article no. 02A900060), ideally in the immediate vicinity of the controlling data logger. The ground connection (GND) of the wiper control unit must be connected both to the ground of the power supply and to the control ground of the data logger.

The power supply of the Wiper DL must be between 9 and 24 volts DC and be able to supply around 90 mA during a wiping operation, as well as up to 500 mA for a short time if the wiper arm jams.



Control unit



Connection box

### Handling instructions for connections

- Pins and sockets must be clean before plugging together.
- Lubricate the pins regularly with a small amount of silicone spray.
- Do not use penetrating oil on or near the connection. This will cause permanent damage.
- Ensure correct alignment before plugging together.
- Never pull on the cable when disconnecting. Do not twist or kink it, always pull it straight.

### Securing the wiper cable

Secure the wiper connection cable with cable ties to prevent snagging and soiling.

#### **⚠ CAUTION**

**Make sure that the cable does not constantly move with the current, as this can lead to material fatigue and ultimately failure.**

## 3.3 Adjusting the wipe angle

Both the wipe angle and the park angle of your Wiper DL have been adjusted at the factory to the sensor for which it was developed. However, there may be situations in which you want to change these angles. This may be the case, for example, if you convert your Wiper DL for use with another instrument.

To adjust the wiping or parking angle, identify the blue controls as shown below.

#### **⚠ WARNING**

**Ensure that the control module is disconnected from the power supply before making any adjustments.**

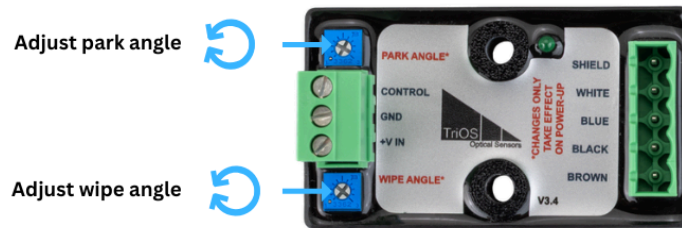

The following applies to both controls: Turning clockwise increases the angle. Turning counterclockwise reduces the angle.

The **parking angle** determines where the wiper comes to a standstill between wipes.

The **wiping angle** determines how far the wiper wipes.

## 3.4 Installation instructions

### NOTICE

For the heavier sensors, e.g. the enviroFlu and the photometers, please note that the two brackets for external attachment of the Wiper DL cannot be attached as the total weight of the Wiper DL and the sensor is too high for these brackets.

In these cases, the Wiper DL is clamped to the sensor and the weight of the sensor and Wiper DL is borne by the sensor mounting method.

With the smallest sensors (e.g. microFlu or TTurb), however, it is possible to use the brackets for external mounting as an option.

Please refer to the following installation instructions.

#### List of installation instructions

- Photometer with 2 mm path length
- Photometer with 5 mm path length
- Photometer with 10 mm path length
- Photometer with 50 mm path length
- Fluorometer microFlu
- Fluorometer nanoFlu
- Fluorometer enviroFlu
- Turbidity sensor TTurb

Photometer with 2 mm path length

Component no.	Part number	Designation
1	02A900001	Wiper DL30
2	02A900011	Brush for photometer with 2 mm path length
3	02A900040	Wiper clamp for photometer with 2/5/10 mm path length

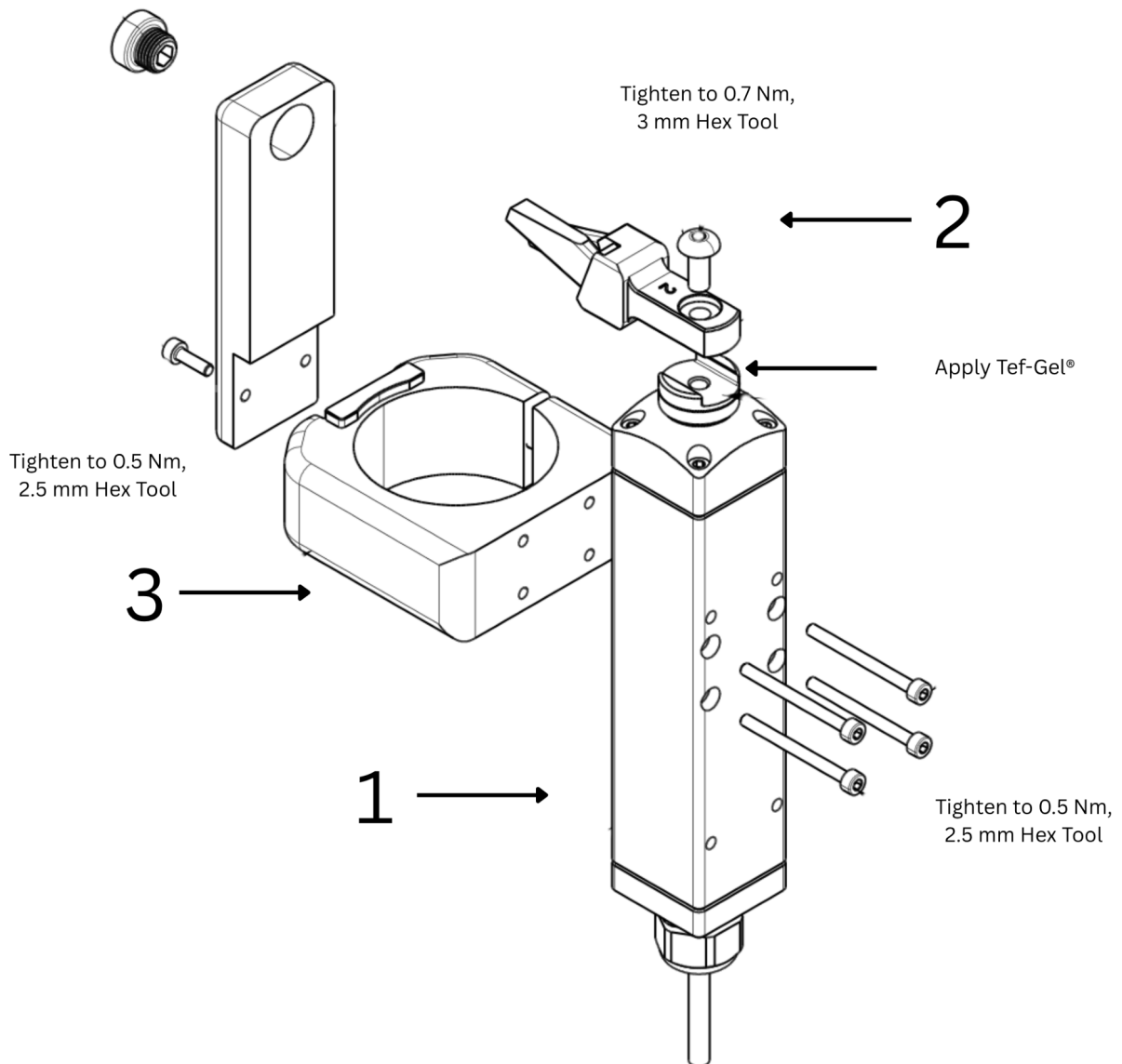

## Photometer with 5 mm path length

Component no.	Part number	Designation
1	02A900001	Wiper DL30
2	02A900012	Brush for photometer with 5 mm path length
3	02A900040	Wiper clamp for photometers with 2/5/10 mm path length

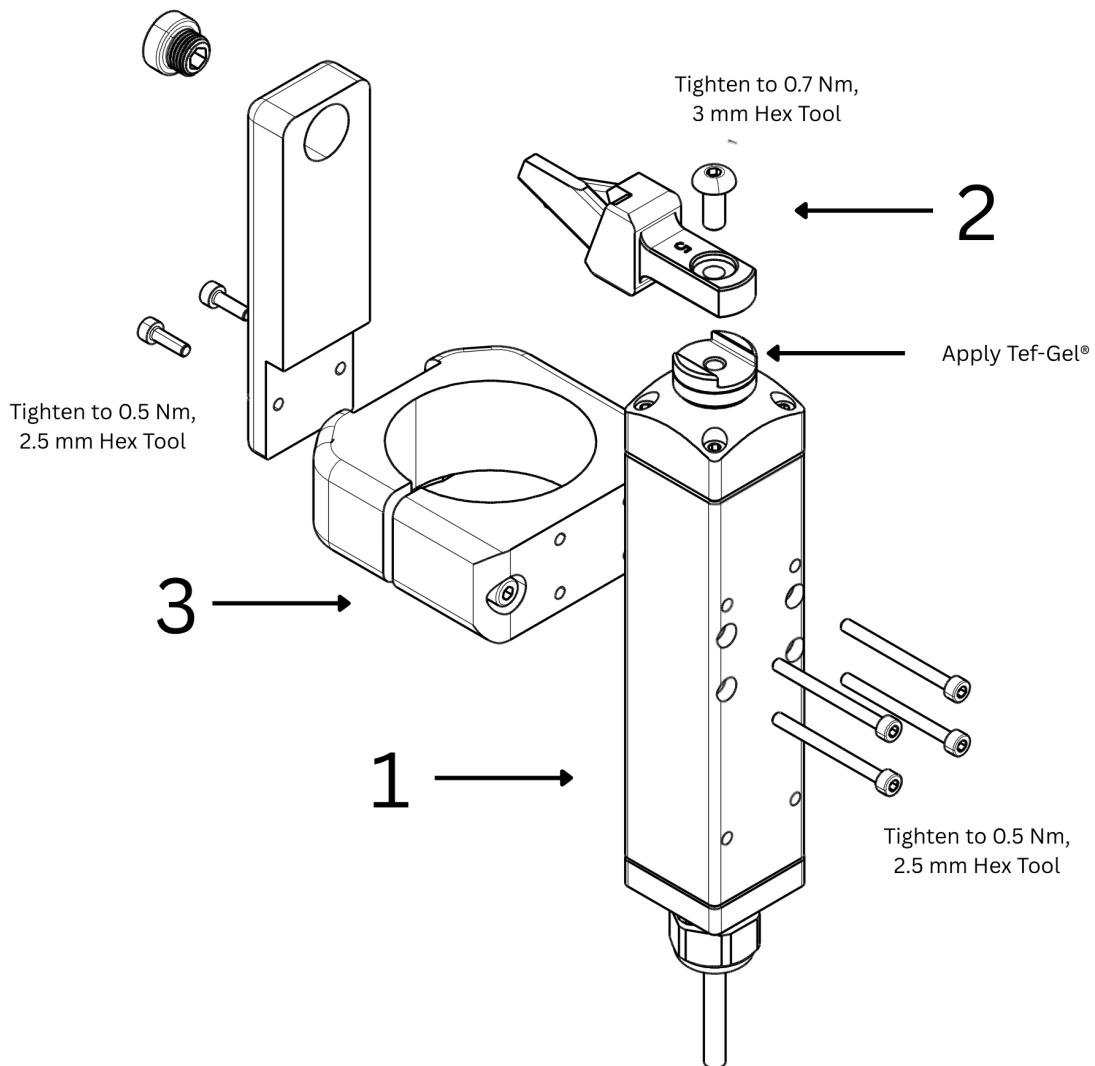

Photometer with 10 mm path length

Component no.	Part number	Designation
1	02A900001	Wiper DL30
2	02A900013	Brush for photometer with 10 mm path length
3	02A900040	Wiper clamp for photometers with 2/5/10 mm path length

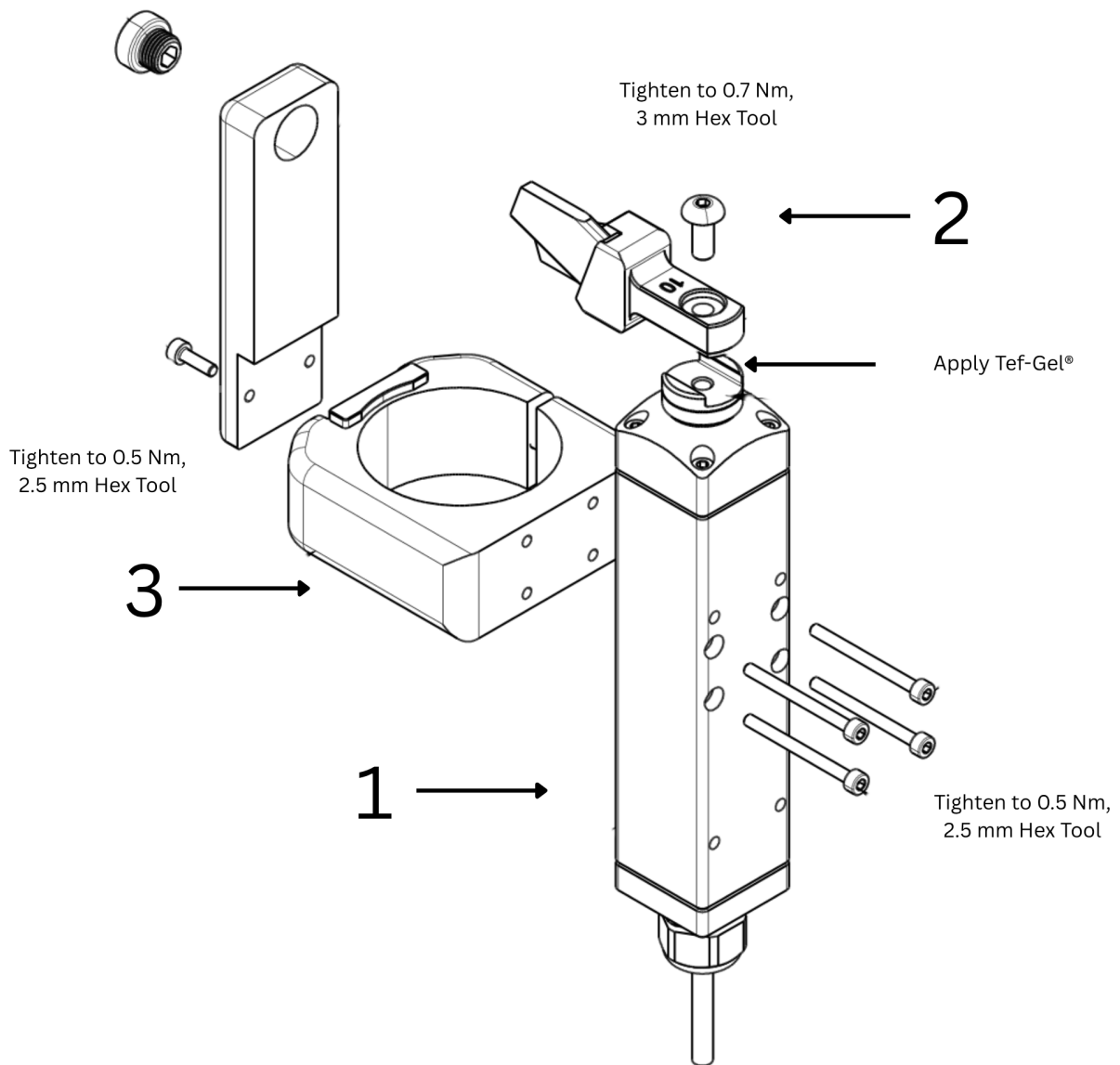

## Photometer with 50 mm path length

Component no.	Part number	Designation
1	02A900001	Wiper DL30
2	02A900015	Brush for photometer with 50 mm path length
3	02A900041	Wiper clamp for photometer with 50 mm path length

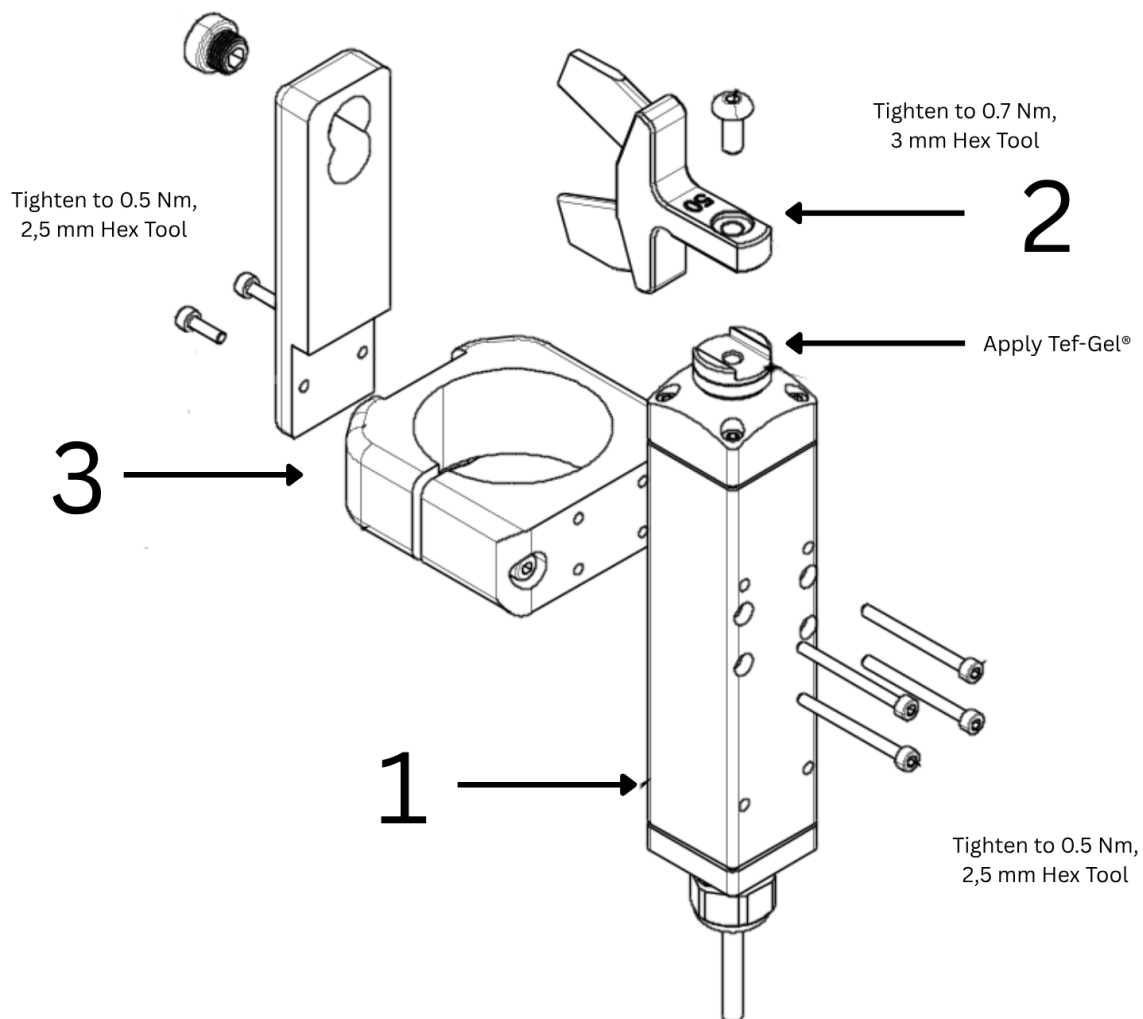

microFlu

Component no.	Part number	Designation
1	02A900001	Wiper DL30
2	02A900021	Brush for fluorometer microFlu
3	02A900043	Wiper clamp for fluorometer microFlu

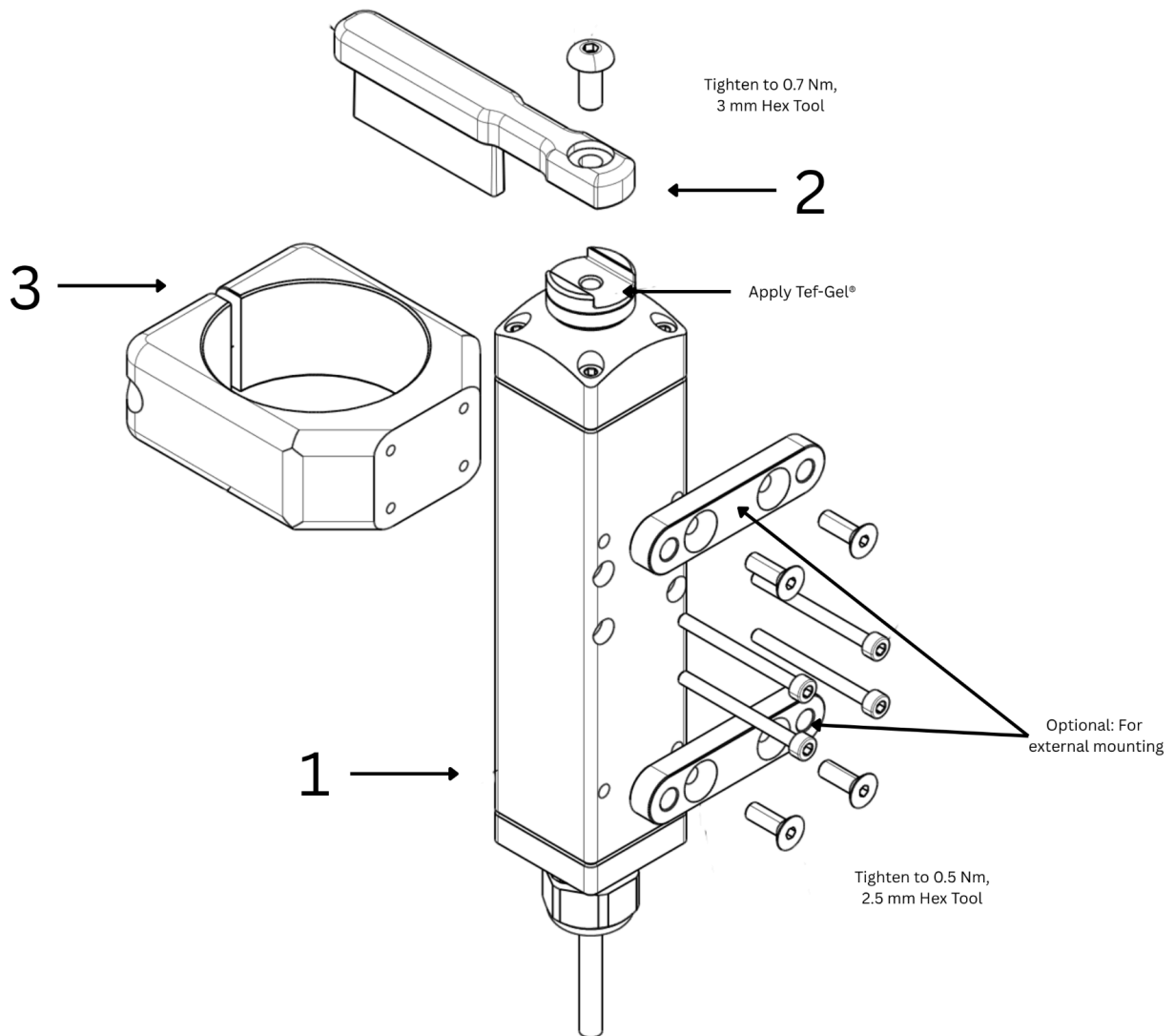

## nanoFlu

Component no.	Part number	Designation
1	02A900001	Wiper DL30
2	02A900022	Brush for nanoFlu
3	02A900044	Wiper clamp for nanoFlu

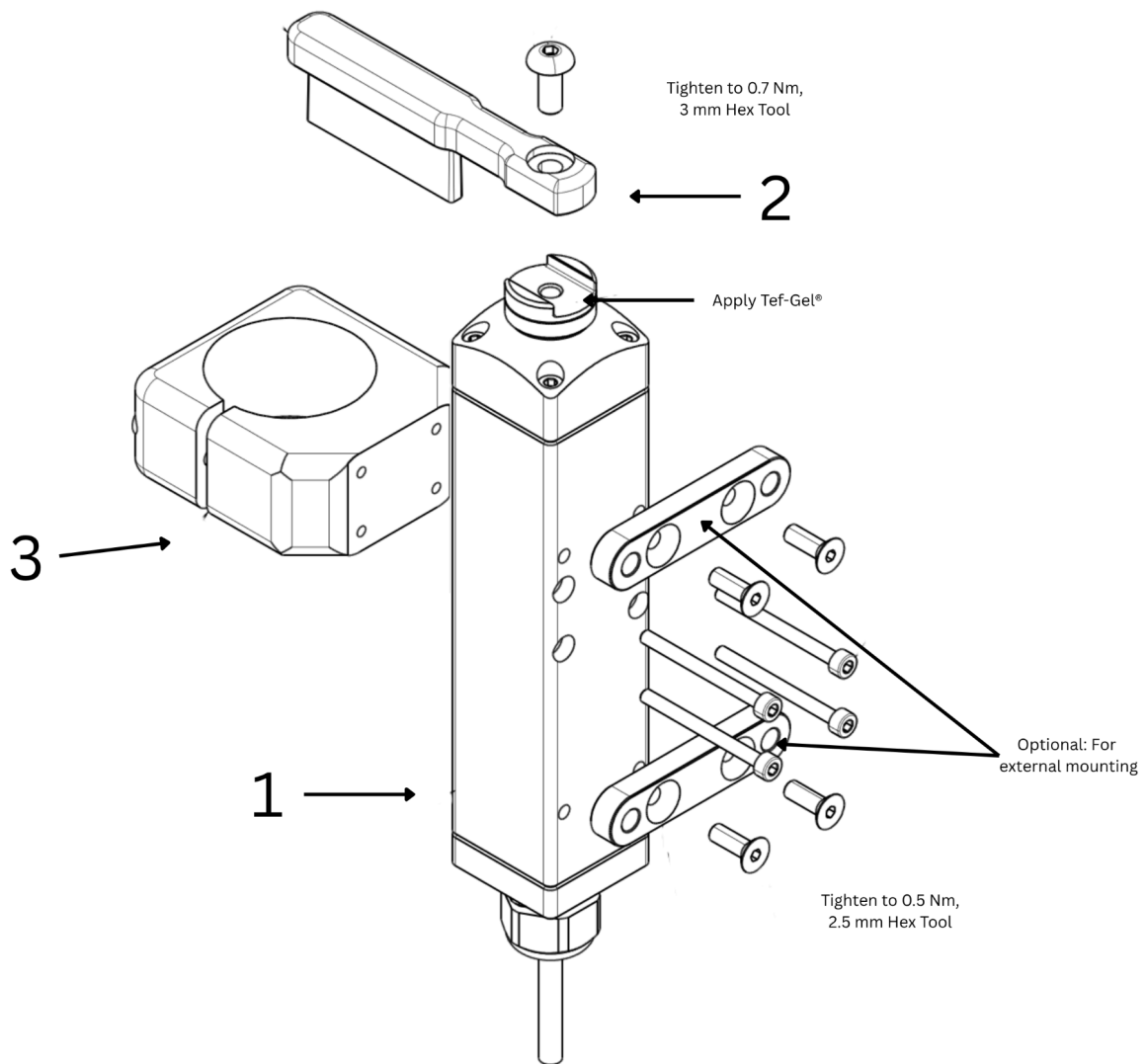

enviroFlu

Component no.	Part number	Designation
1	02A900001	Wiper DL30
2	02A900020	Brush for enviroFlu
3	02A900042	Wiper clamp for enviroFlu

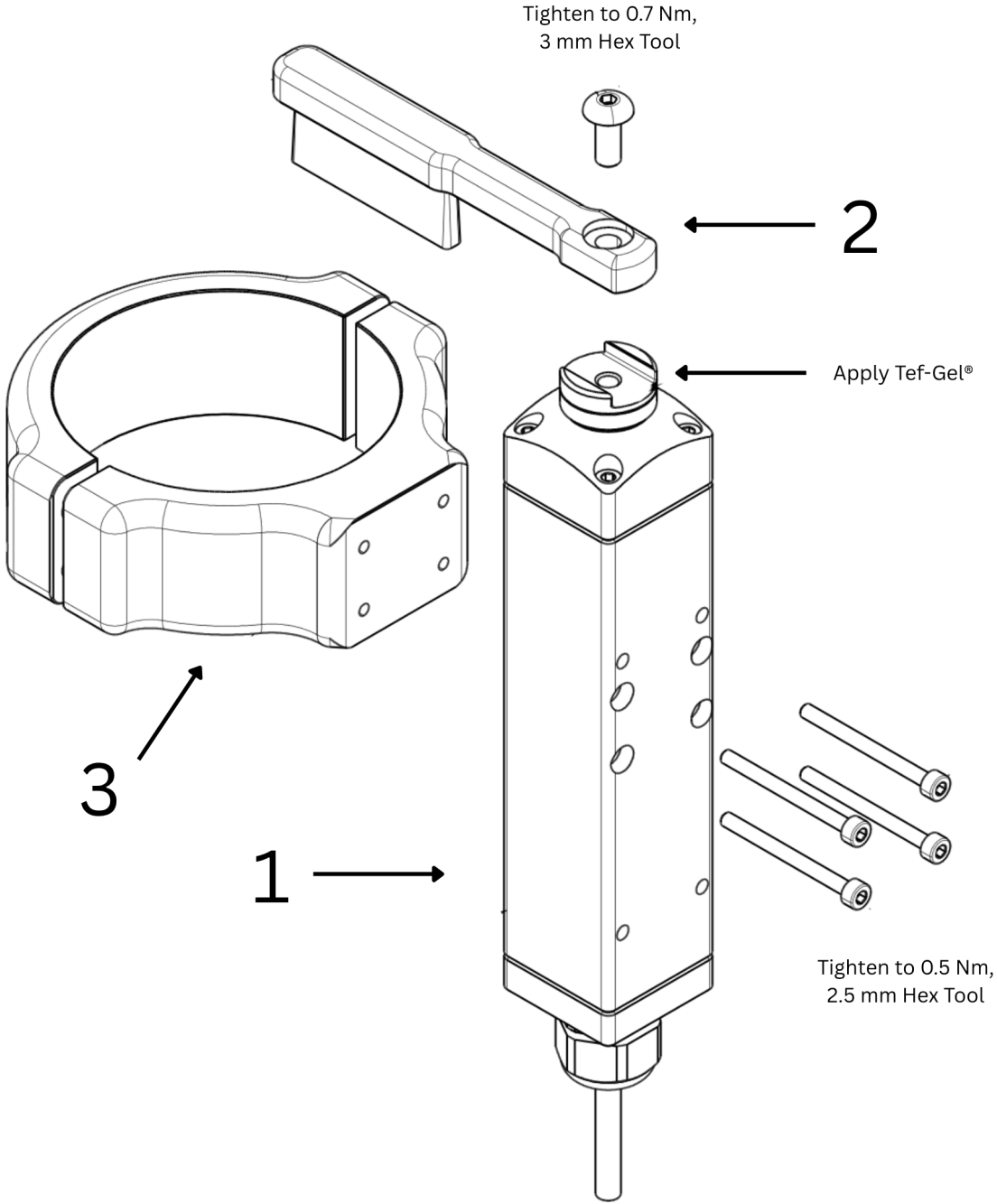

## TTurb

Component no.	Part number	Designation
1	02A900001	Wiper DL30
2	02A900030	Brush for TTurb
3	02A900045	Wiper clamp for TTurb

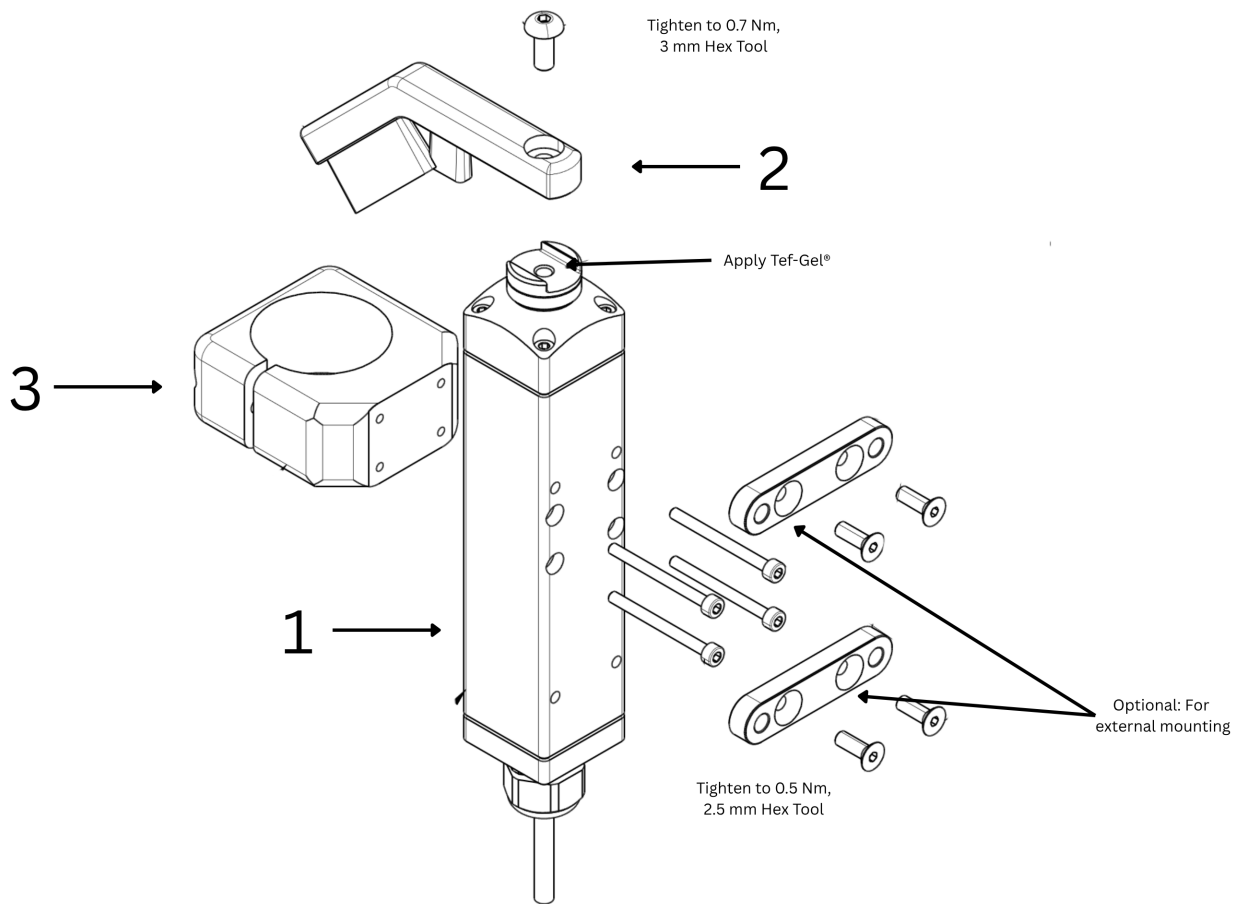

## 4 Application

### 4.1 LED status indicator

When the Wiper DL is switched on, the LED status indicator flashes four times, after which a wipe is performed. During operation, the LED flashes every 15 seconds. The number of flashes indicates the operating status of the Wiper DL.

During normal operation, the LED flashes once. If there is an error, the LED flashes twice, as shown in the following table.

LED flashing sequence	Status description
Once every 15 seconds	Normal operation
Twice every 15 seconds	The previous wiping process has failed

#### Integrated self-monitoring for reliable operation

Unpredictable events can occur during operation. The Wiper DL has been designed to withstand the harsh conditions of field use.

- The drive shaft of the wiper has a slip mechanism so that the wiper arm can be moved manually if necessary without causing damage. This also protects the wiper gearbox from damage if the wiper arm is subjected to force or shock loads during use.
- The Wiper DL continuously monitors the position of the wiper arm. If the wiper arm is unintentionally moved in front of the optical window of the sensor, the wiper detects this and moves the wiper arm to the side.
- If the wiper arm becomes jammed at any time during a wipe, the direction of rotation is reversed to clear the obstruction. If this is unsuccessful, the Hydro-Wiper aborts the wiping process. The diagnostic LED flashes twice every 15 seconds as long as this situation persists.

#### **NOTICE**

**The Wiper DL constantly monitors the position of the wiper arm. If the wiper arm is unintentionally moved in front of the sensor, the wiper recognizes this and pushes the wiper arm to the side.**

### 4.2 Operating the Wiper DL

When switched on, the wiper arm first rotates to the starting position, if it is not already there. From the starting position, the brush wipes over the surface of the optical instrument and then returns to the starting position.

The Wiper DL waits until it receives a control pulse from the data logger before it performs another wipe. The current consumption of the wiper between wipes is very low at around 0.06 mA.

When the control line of the wiper module is set to high (+5 volts) by the data logger, a wiping process is triggered. The brush wipes over the surface of the optical window, stops and then wipes in the opposite direction back to the start position. A wipe usually takes about 10 seconds.

After the control line has been set to high, it must go to low (0 volts) before it is set to high again to trigger another wipe. If the control line remains high, no further wiping process takes place until the control line goes low and then high again.

The optimum frequency of wiping the optical instrument depends on the degree of soiling and the application. Under typical conditions, a wiping interval of 2 to 4 hours should be sufficient to prevent soiling; however, this can be extended or shortened depending on the conditions on site.

The optimum time for wiping is immediately before taking a measurement with the optical instrument. It is recommended to take a short break between wiping and the measurement to allow any residue removed during wiping to settle. The LED on the wiper control module flashes every 15 seconds when the hydro wiper is working properly.

## 5 Calibration

Not applicable for this device.

## 6 Malfunction and maintenance

### 6.1 Maintenance of the wiper

Your Wiper DL is extremely low-maintenance and should give you many years of reliable service.

#### Replaceable parts of the wiper

The only replaceable parts are the wiper strip (brush) and the anode button.

Under normal conditions, the brush should last for many thousands of wipes. However, should your brush need to be replaced, spare parts are available at low cost and directly from TriOS Mess- und Datentechnik GmbH.

Anodes reduce corrosion of the wiper shaft in harsh environments. Replacement anode buttons can be purchased from TriOS Mess- und Datentechnik GmbH. To replace the anode knob, simply screw off the old one and replace it.

### 6.2 Troubleshooting

#### Malfunction of the wiper operation

If the wiper arm becomes jammed during a wipe due to an obstacle, it attempts to free itself by changing direction a number of times. If this is not successful, the wiping process is aborted and the LED flashes twice every 15 seconds until the next wipe is due.

#### **NOTICE**

**The Wiper DL will not be damaged if the wiper arm becomes completely jammed by an obstacle.**

#### **NOTICE**

**The LED indicator flashes twice every 15 seconds if the Wiper DL has not completed the last scheduled wipe.**

### 6.3 Return shipment

Please note the procedure for your return shipment.

If you are returning a sensor or device, please use the URL [trios.de/rma](https://trios.de/rma) to go to our **online form**, which you can use to register your return shipment to TriOS **technical support**.

To ensure a smooth return shipment process, please complete the online form in full. Please note the mandatory fields, otherwise the form cannot be sent. The system **automatically assigns an RMA number**.

After submitting your entries, you will immediately receive an e-mail with the data you have entered, a link to **free DHL shipping** and a label with the **RMA number of your case**.

Please make sure you stick this label **clearly visible on the outside of your return package** so that the package can be assigned more quickly.



**Please note! Return shipments without an RMA number cannot be accepted and processed!**

Please note that sensors or devices may need to be cleaned and disinfected before shipping.

In order to ship the goods undamaged, use the original packaging. If this is not available, make sure that safe transportation is guaranteed and that the device is secured with sufficient packing material.

We will contact you as soon as possible after receipt of the return shipment.

## 7 Technical data

### 7.1 Technical specifications

<b>Brush construction</b>	PVC shaft, nylon bristles; user-replaceable	
<b>Housing material</b>	Acetal (POM) with titanium shaft	
<b>Dimensions (L x Ø)</b>	~ 206 x 41 mm	~ 8.1 x 1.6'
<b>Weight wiper</b>	0.3 kg*	0.66 lbs*
<b>Weight cable 10 m</b>	0.36 kg	0.79 lbs
<b>Path lengths</b>	2 mm, 5 mm, 10 mm, 20 mm, 50 mm	

\*Wiper DL30, housing only, without brush, without brackets, without cable and without plug

#### Wiper controller

<b>Supply voltage</b>	9 – 24 VDC	
<b>Power consumption between wipes</b>	0.06 mA	
<b>Power consumption during wiping</b>	~ 90 mA typical	

<b>Max. Pressure</b>	<b>Immersion depth 30 m</b>	3 bar	~ 45.5 psi
	<b>Immersion depth 200 m</b>	20 bar	~ 290.1 psi
<b>Degree of protection</b>	IP68		
<b>Operating temperature</b>	+2...+40 °C	+35.6 to +104 °F	
<b>Storage temperature</b>	-10...+70 °C	+14 to +158 °F	

<b>Maintenance effort</b>	≤ 0.5 h/month typical
<b>Maintenance interval</b>	Depending on application
<b>Warranty</b>	1 year (EU & USA: 2 years)

## 8 Accessories

### 8.1 Accessories and spare parts Wiper DL

Weatherproof connection box for mounting and connecting the wiper control unit to the wiper cable and the connection cable.



Connection cable between control module and (TriOS) controller by the meter;  
Open end / open cores

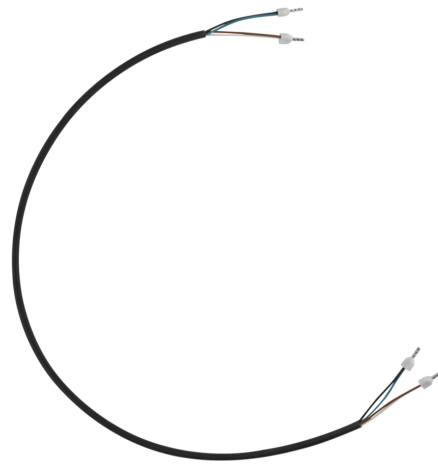

Connection cable SubConn MCIL5F / open wires  
available in 10 m, 25 m, 50 m

not shown

Wiper brush in various designs to match the optical measuring device



Wiper terminals in various versions to match the optical measuring device



## 9 Warranty

The warranty period for our devices within the EU and the USA is 2 years from the date of invoice. Outside the EU it is 1 year. Excluded from the warranty are all normal consumables (depending on the product, e.g. light sources or windows).

**The warranty is subject to the following conditions:**

- The device and all accessories must be installed as described in the relevant manual and operated in accordance with the specifications.
- Damage caused by contact with aggressive and material-damaging substances, liquids or gases, as well as transport damage, are not covered by the warranty.
- Damage caused by improper handling and use of the device is not covered by the warranty.
- Damage caused by modification or unprofessional attachment of accessories by the customer is not covered by the warranty.

**NOTICE**

**Opening the device will void the warranty!**

## 10 Technical support

If you have a problem with a TriOS sensor / a TriOS device, please contact TriOS technical support.

We recommend sending in sensors every 2 years for maintenance and calibration. When returning devices, please be sure to follow the procedure described in Chapter 6.

### Contact technical support:

E-mail: [support@trios.de](mailto:support@trios.de)

Phone: +49 (0) 4402 69670 - 0

Fax: +49 (0) 4402 69670 - 20

To enable us to help you quickly, please send us the sensor ID number (serial number with 8 digits, consisting of letters and numbers, e.g. 6700003F) by e-mail.

## 11 Contact us

We are constantly working on improving our devices. Please visit our website for the latest news.

If you have found a fault in one of our devices or programs or would like additional functions, please contact us:

Technical Support:	<a href="mailto:support@trios.de">support@trios.de</a>
General questions/sales:	<a href="mailto:sales@trios.de">sales@trios.de</a>
Website:	<a href="http://www.trios.de">www.trios.de</a>

### **TriOS Mess- und Datentechnik GmbH**

Bürgermeister-Brötje-Str. 25

26180 Rastede

Rastede, Germany

Telephone

+49 (0) 4402 69670 - 0

Fax

+49 (0) 4402 69670 - 20

# 12 Index

## A

Accessories.....	25, 25
angle.....	9
anode button.....	22
arm.....	19

## C

Certificates and approvals.....	5
Contact us.....	28
control unit.....	8
copyright.....	3

## D

disposal.....	5
---------------	---

## E

Electromagnetic waves.....	4
----------------------------	---

## H

Health and safety instructions.....	3
-------------------------------------	---

## I

Installation instructions.....	10
--------------------------------	----

## L

LED status.....	19
-----------------	----

## M

Maintenance.....	22
Malfunction.....	22

## O

operating requirements.....	4
-----------------------------	---

## P

Product identification.....	7
-----------------------------	---

## R

Return shipment.....	22
----------------------	----

## S

Scope of delivery.....	6
self-monitoring.....	19

## T

Technical support.....	27, 28
type plate.....	7

## W

Warning notices.....	4
Warranty.....	26
wipe angle.....	9
wiper arm.....	19

## 13 Appendix

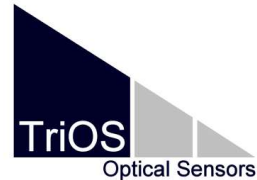

Hersteller/Manufacturer/Fabricant: TriOS Mess- und Datentechnik GmbH  
 Bürgermeister-Brötje-Str. 25  
 D- 26180 Rastede

## Konformitätserklärung Declaration of Conformity Déclaration de Conformité

Die TriOS GmbH bescheinigt die Konformität für das Produkt  
 The TriOS GmbH herewith declares conformity of the product  
 TriOS GmbH déclare la conformité du produit

Bezeichnung Product name Désignation	<b>Wischer</b>
Typ / Type / Type	DL30 DL200
Mit den folgenden Bestimmungen With applicable regulations Avec les directives suivantes	2006/42/EG Maschinenrichtlinie 2014/30/EU EMV-Richtlinie 2011/65/EU RoHS-Richtlinie + (EU) 2015/863 + (EU) 2017/2102
Angewendete harmonisierte Normen Harmonized standards applied Normes harmonisées utilisées	EN ISO 12100:2010 EN 61000-6-4:2019 EN 61000-6-2:2019 EN IEC 63000:2018
Datum / Date / Date  18.05.2026	Unterschrift / Signature / Signature   R. Heuermann

D05-930yy202605

Seite 1 von 1

TriOS Mess- und Datentechnik GmbH  
Bgm.-Brötje-Str. 25 · 26180 Rastede · Deutschland  
Tel +49 (0)4402 69670-0  
Fax +49 (0)4402 69670-20  
[info@trios.de](mailto:info@trios.de)  
[www.trios.de](http://www.trios.de)